

**SANITARY PRESSURE REDUCING VALVE  
P130H**

**DESCRIPTION**

The ADCA P130H series direct acting, spring-loaded diaphragm sensing, balanced plug, pressure reducing valves are designed for use with clean air, nitrogen, carbon dioxide, oxygen, argon and other gases or liquids compatible with the construction materials and valve design.

This valve is specifically designed for the high purity gas systems found in the pharmaceutical, cosmetic, fine chemical and food & beverage processes.

**MAIN FEATURES**

- Compact design.
- Completely machined from 316L stainless steel bar stock, no castings or forgings are used.
- FDA / USP Class VI compliant seals.
- Non-rising adjustment knob.

**STANDARD SURFACE FINISH**

- Internal wetted parts:  $\leq 0,51$  micron Ra – SF1.
- External:  $\leq 0,76$  micron Ra – SF3.
- Other surface conditions see IS PV20.00 E – Technical information.
- Ultrasonic cleaning.

- OPTIONS:**
- Self relieving.
  - Leakage line connection 1/8" (captured vent).
  - Gauge connection on body.
  - Different soft valves for liquids and gases.

- USE:**
- Clean air, nitrogen, carbon dioxide, oxygen, argon and other gases or liquids compatible with the construction.

- AVAILABLE MODELS:**
- P130H.

- SIZES:**
- 1"; DN 25.

- REGULATING RANGES:**
- 0,2 – 1,5 bar; 0,3 – 3 bar; 2 – 8 bar.

- CONNECTIONS:**
- ASME BPE, DIN and ISO clamp ferrules or tube weld (ETO) ends.
  - Others on request.

- PACKAGING:**
- Assembling and packaging in a clean room certified according to ISO 14644-1.
  - The product is end capped and sealed with recyclable thermo-shrinkable plastic film, to avoid contamination.

- INSTALLATION:**
- Horizontal installation recommended.
  - See IMI – Installation and maintenance instructions.

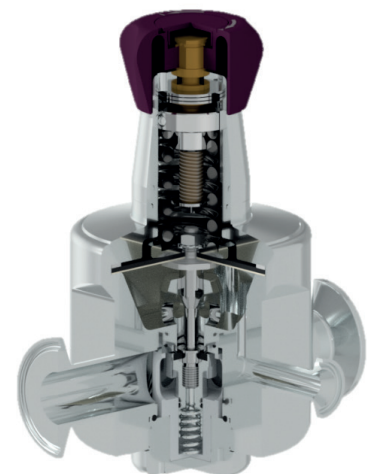

LIMITING CONDITIONS	
<b>Valve model</b>	<b>P130H</b>
Body design conditions	PN 16
Maximum upstream pressure	16 bar
Maximum downstream pressure	8 bar
Minimum downstream pressure	0,2 bar
Maximum design temperature *	150 °C

\* Others on request.

CE MARKING – GROUP 2 (PED – European Directive)	
<b>PN 16</b>	<b>Category</b>
1" – DN 25	SEP

**FLOW RATE COEFFICIENTS (m<sup>3</sup>/h) \***

	ASME BPE	DIN	ISO
<b>SIZE</b>	<b>1"</b>	<b>DN 25</b>	<b>DN 25</b>
<b>Kvs</b>	4,2	4,2	4,2

\* Reduced Kvs on request.

**DIMENSIONS (mm) ASME BPE**

SIZE	A	B	C	D	d1	d2	E	F	H	WEIGHT (kg) *
1"	148	42	146	100	25	15,75	78,5	50,5	22,1	5,14

\* Valves with nylon adjustment knob weigh 0,3 kg less.

**DIMENSIONS (mm) DIN**

SIZE	A	B	C	D	d1	d2	E	F	H	WEIGHT (kg) *
DN 25	135	42	146	100	25	15,75	78,5	50,5	26	5,17

\* Valves with nylon adjustment knob weigh 0,3 kg less.

Remarks: Clamp ferrules according to DIN 32676-A; Tube weld (ETO) according to DIN 11866-A (DIN 11850-2).

**DIMENSIONS (mm) ISO**

SIZE	A	B	C	D	d1	d2	E	F	H	WEIGHT (kg) *
DN 25	135	46	142	100	25	15,75	78,5	50,5	29,7	5,16

\* Valves with nylon adjustment knob weigh 0,3 kg less.

Remarks: Clamp ferrules according to DIN 32676-B; Tube weld (ETO) according to DIN 11866-B (ISO 1127).

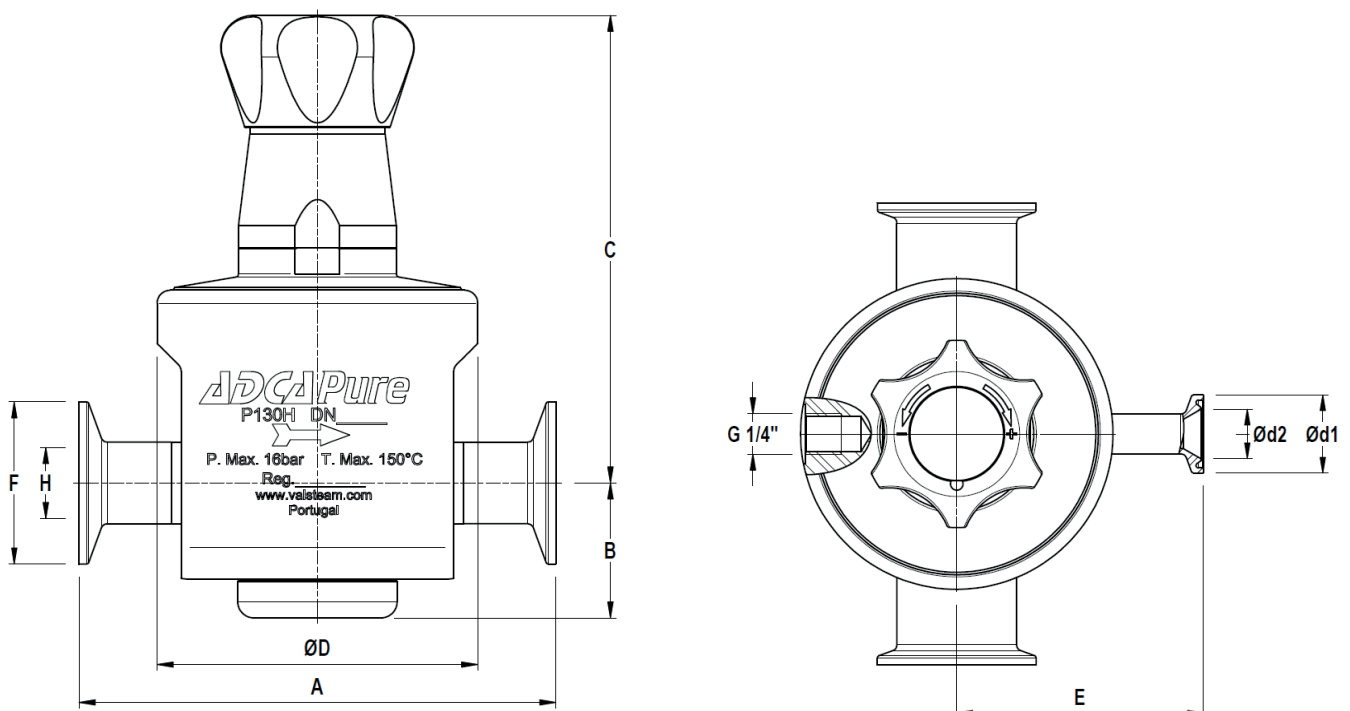

*Optional pressure gauge connection.*

**MATERIALS**

POS. N°	DESIGNATION	MATERIAL
1	Valve body	AISI 316L / 1.4404
2	Cover	AISI 316L / 1.4404
3	Spring cover	AISI 316L / 1.4404
4	Seat cover	AISI 316L / 1.4404
5	* O-ring	EPDM
6	* Piston	AISI 316L / 1.4404
7	* Valve head	AISI 316L / 1.4404 ; Viton ; PTFE
8	* O-ring	EPDM
9	* Valve spring	AISI 316 / 1.4401 electropolished
10	* Seat	AISI 316L / 1.4404
11	* O-ring	EPDM
12	* Guide	TFM 1600
13	* Stem	AISI 316L / 1.4404
14	Pusher disc	AISI 316L / 1.4404
15	* Lower diaphragm	PTFE (Gylon)
16	* Upper diaphragm	EPDM
17	Washer	AISI 304 / 1.4301
18	Spring plate	AISI 304 / 1.4301
19	Nut	Stainless steel A2-70
20	* Adjustment spring	AISI 302 / 1.4300
21	Spring plate	AISI 304 / 1.4301
22	Adjustment screw	Brass
23	Retaining washer	Stainless steel A2-70
24	Adjustment knob	AISI 316L / 1.4404
		Nylon
25	O-ring	NBR
26	** O-ring	EPDM
27	Bearing	Corrosion resistant steel
28	Ext. bowed shaft ring	Stainless steel
29	Cover nut	Plastic

\* Available spare parts ; \*\* If applicable.

Remarks: FDA / USP Class VI seals certificate on request.

All valves have a serial number. In case of non-standard valves, this number must be supplied if spare parts are ordered.

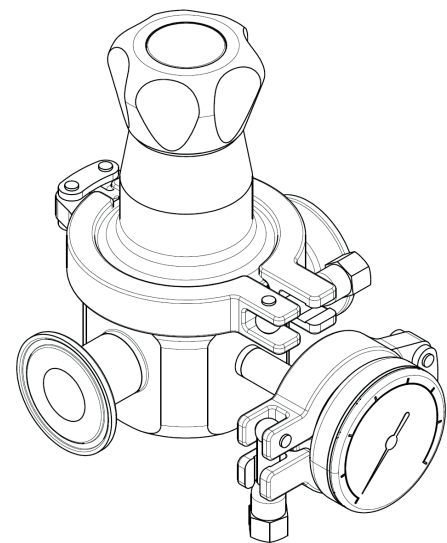
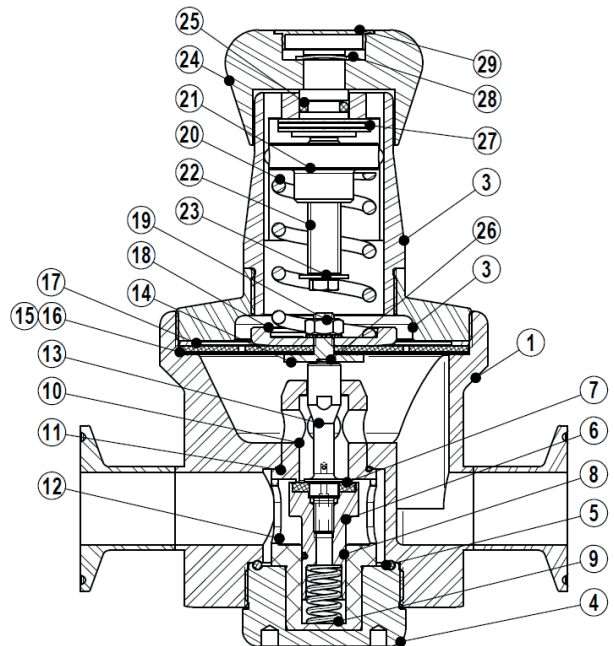

*Optional pressure gauge connection.*

ORDERING CODES P130H													
Valve model	P3H	1	2	T	M	X	I	X	X	X	DI	25	
P130H – AISI 316L / 1.4404 diaphragm sensing pressure reducing valve	P3H												
<b>Regulating range</b>													
0,2 to 1,5 bar		1											
0,3 to 3 bar		2											
2 to 8 bar		3											
<b>Flow rate coefficient</b>													
Kvs 4,2			2										
<b>Diaphragm</b>													
PTFE (Gylon)					T								
EPDM (non-standard)					E								
<b>Seat material</b>													
Metal to metal (non-standard)					M								
EPDM					E								
PTFE					T								
FPM / Viton (FDA approval only)					V								
<b>Relieving</b>													
Non-relieving						X							
Relieving (only for non-dangerous gases)						R							
Relieving with captured vent						L							
<b>Adjustment knob and top cap</b>													
Stainless steel adjustment knob							I						
Nylon adjustment knob							P						
Top cap (adjustment screw with cover)							T						
<b>Gauge port options</b>													
Without gauge ports								X					
Tri-clamp gauge port on the left side (rel. to the flow direction) – downstream pressure									7				
Tri-clamp gauge port on the right side (rel. to the flow direction) – downstream pressure										6			
Tri-clamp gauge port on both sides – downstream pressure											5		
Threaded gauge port on the left side (rel. to the flow direction) – downstream pressure – ISO 7 Rp 1/4"												4	
Threaded gauge port on the right side (rel. to the flow direction) – downstream pressure – ISO 7 Rp 1/4"													3
Threaded gauge port on both sides – downstream pressure – ISO 7 Rp 1/4"													2
Threaded gauge port on the left side (rel. to the flow direction) – downstream pressure – 1/4" NPT													W
Threaded gauge port on the right side (rel. to the flow direction) – downstream pressure – 1/4" NPT													Y
Threaded gauge port on both sides – downstream pressure – 1/4" NPT													Z
<b>Surface finish a)</b>													
Standard surface finish												X	
Mirror mechanical polished external surfaces (SF1)													P
Electropolished internal wetted parts (SF5)													E
<b>Special features</b>													
None													X
Degreased for oxygen													O
<b>Pipe connection</b>													
Clamp ferrule ASME BPE													D
Clamp ferrule DIN (DIN 32676-A)													F
Clamp ferrule ISO (DIN 32676-B)													E
Tube weld (ETO) according to ASME BPE													DI
Tube weld (ETO) according to DIN 11866-A (DIN 11850-2)													FI
Tube weld (ETO) according to DIN 11866-B (ISO 1127)													EI
<b>Size</b>													
1" or DN 25													25
<b>Special valves / Extras</b>													
Full description or additional codes have to be added in case of non-standard combination													E

a) Consult IS PV20.00 for further details and other surface finish options.