

## SANITARY PRESSURE REDUCING VALVE P161

### DESCRIPTION

The ADCAPure P161 is a series of angle design direct acting diaphragm sensing pressure reducing valves. These regulators, available with spring or dome-loading, are designed for use with clean steam, compressed air, water and other gases or liquids compatible with the construction materials and valve design.

### MAIN FEATURES

Spring or dome-loaded.  
Non-rising adjustment knob.  
Compact design with clamped body.  
Available with low pressure diaphragm.  
FDA / USP Class VI compliant seals.  
Completely machined from bar stock material, no castings or forgings are used.

### STANDARD SURFACE FINISH

Internal wetted parts:  $\leq 0,51$  micron Ra – SF1.  
External:  $\leq 0,76$  micron Ra – SF3.  
Other surface conditions see IS PV20.00 E – Technical information.  
Ultrasonic cleaning.

**OPTIONS:** Leakage line connection (1/4").  
Different soft sealings for liquids and gases.  
Lock system, allows inline clean-in-place (CIP) and sterilization-in-place (SIP) operations.  
Gauge connection on body.  
Top cap (adjustment screw with cover).  
Dome-loaded version.

**USE:** Clean steam, compressed air, water and other gases and liquids compatible with the construction.

**AVAILABLE MODELS:** P161.

**SIZES:** 1/2" to 2"; DN 15 to 50.

**REGULATING RANGES:** 0,3 to 1,1 bar; 0,8 to 1,5 bar; 1 to 3 bar; 1,5 to 5 bar.

**CONNECTIONS:** ASME BPE, DIN and ISO clamp ferrules or tube weld (ETO) ends. Others on request.

**PACKAGING:** Assembling and packaging in a clean room certified according to ISO 14644-1. The product is end capped and sealed with recyclable thermo-shrinkable plastic film, to avoid contamination.

**INSTALLATION:** Horizontal installation. Vertical inlet and horizontal outlet. See IMI – Installation and maintenance instructions.

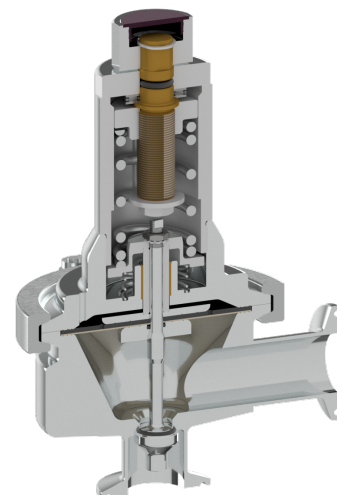

LIMITING CONDITIONS	
Valve model	<b>P161</b>
Body design conditions	PN 16
Maximum upstream pressure	8 bar
Maximum downstream pressure	5 bar
Minimum downstream pressure *	0,3 bar
Maximum operating temperature **	180 °C

\* For tight shut off, with adjustment spring relaxed, ensure a minimum downstream pressure of 0,2 bar.

\*\* With PTFE diaphragm and seals. Consult the manufacturer in case of other materials.

CE MARKING – GROUP 2 (PED – European Directive)	
PN 16	Category
1/2" to 2" – DN 15 to 50	SEP

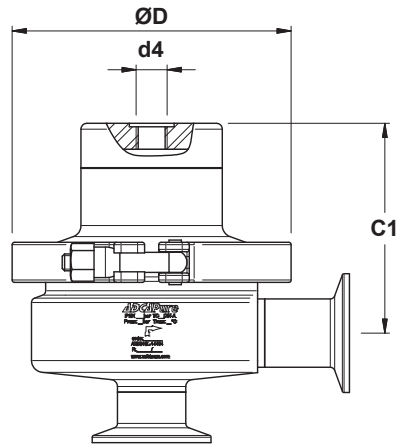
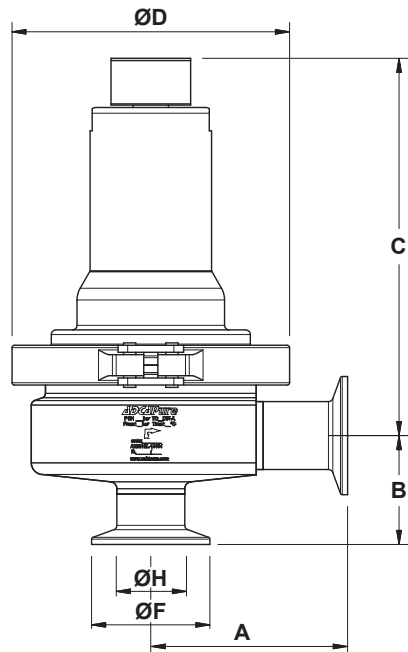

Optional dome-loaded version

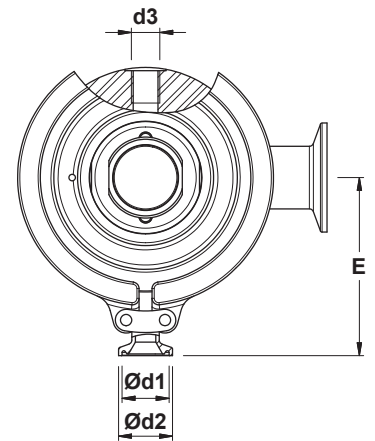

Optional pressure gauge connections

**DIMENSIONS (mm) ASME BPE**

SIZE	REGULATING RANGES 0,8 to 1,5 bar, 1 to 3 bar and 1,5 to 5 bar												REGULATING RANGE 0,3 to 1,1 bar				
	A	B	C	C1	D	d1	d2	d3 *	d4 *	E	F	H	WGT. (kg)	A	D	E	WGT. (kg)
1/2"	77	53	156	84	119	15,75	25	1/4"	1/4"	83	25	9,4	4,1	85	134	91	4,9
3/4"	77	56	160	88	119	15,75	25	1/4"	1/4"	83	25	15,75	4,4	85	134	91	5,1
1"	77	52	163	91	119	15,75	25	1/4"	1/4"	83	50,5	22,1	4,6	85	134	91	5,4
1 1/2"	85	61	204	124	134	15,75	25	1/4"	1/4"	96	50,5	34,8	8	101	170	109	11,1
2"	85	67	207	127	134	15,75	25	1/4"	1/4"	96	64	47,5	8,6	101	170	109	12

**DIMENSIONS (mm) DIN**

SIZE	REGULATING RANGES 0,8 to 1,5 bar, 1 to 3 bar and 1,5 to 5 bar												REGULATING RANGE 0,3 to 1,1 bar				
	A	B	C	C1	D	d1	d2	d3 *	d4 *	E	F	H	WGT. (kg)	A	D	E	WGT. (kg)
DN 15	77	45	160	88	119	15,75	25	1/4"	1/4"	83	34	16	4,4	85	134	91	5,1
DN 20	77	40	158	86	119	15,75	25	1/4"	1/4"	83	34	20	4,3	85	134	91	4,9
DN 25	84	47	161	89	119	15,75	25	1/4"	1/4"	83	50,5	26	4,6	92	134	91	5,3
DN 32	84	50	163	91	119	15,75	25	1/4"	1/4"	83	50,5	32	4,8	84	134	83	5,5
DN 40	93	69	202	122	134	15,75	25	1/4"	1/4"	96	50,5	38	8	109	170	109	11
DN 50	93	75	206	126	134	15,75	25	1/4"	1/4"	96	64	50	8,6	109	170	109	12

Remarks: Clamp ferrules according to DIN 32676-A; Tube weld (ETO) according to DIN 11866-A (DIN 11850-2).

**DIMENSIONS (mm) ISO**

SIZE	REGULATING RANGES 0,8 to 1,5 bar, 1 to 3 bar and 1,5 to 5 bar												REGULATING RANGE 0,3 to 1,1 bar				
	A	B	C	C1	D	d1	d2	d3 *	d4 *	E	F	H	WGT. (kg)	A	D	E	WGT. (kg)
DN 15	84	43	159	87	119	15,75	25	1/4"	1/4"	83	50,5	18,1	4,4	92	134	91	5,1
DN 20	84	46	162	90	119	15,75	25	1/4"	1/4"	83	50,5	23,7	4,6	92	134	91	5,4
DN 25	84	49	164	92	119	15,75	25	1/4"	1/4"	83	50,5	29,7	4,8	92	134	91	5,6
DN 32	93	70	202	122	134	15,75	25	1/4"	1/4"	96	64	38,4	8,2	109	170	109	11,3
DN 40	93	75	206	126	134	15,75	25	1/4"	1/4"	96	64	44,3	8,8	109	170	109	12,1

Remarks: Clamp ferrules according to DIN 32676-B; Tube weld (ETO) according to DIN 11866-B (ISO 1127).

\* As standard, connections d3 and d4 are female threaded ISO 7 Rp.

**FLOW RATE COEFFICIENTS (m³/h)**

SIZE	ASME BPE					DIN						ISO						
	1/2"	3/4"	1"	1 1/2"	2"	DN 15	DN 20	DN 25	DN 32	DN 40	DN 50	DN 15	DN 20	DN 25	DN 32	DN 40		
Kvs	1,3	3	4,2	7	7	13	2,1	3	4,2	4,2	7	7	13	2,1	4,2	4,2	7	7

**MATERIALS**

POS. N°	DESIGNATION	MATERIAL
1	Valve body	AISI 316L / 1.4404
2	Cover	AISI 316L / 1.4404
3	Intermediate flange	AISI 316L / 1.4404
3A	Clamp	AISI 316 / 1.4401
4	* Valve stem	AISI 316L / 1.4404
5	* Soft plug	** EPDM; PTFE; FPM
6	* Valve plug	AISI 316L / 1.4404
7	* Upper diaphragm	EPDM
8	* Lower diaphragm	PTFE (Gylon)
9	Diaphragm plate	AISI 316L / 1.4404
10	* O-ring	EPDM
11	Diaphragm plate	AISI 316L / 1.4404
12	Stem guide	AISI 316L / 1.4404
12A	Plain bearing	Bronze
12B	Spring	AISI 302 / 1.4300
13	Spring plate	AISI 316L / 1.4404
14	Nut	AISI 304 / 1.4301
15	Washer	AISI 304 / 1.4301
16	* Adjustment spring	AISI 302 / 1.4300
17	Top spring plate	AISI 316L / 1.4404
18	Retaining washer	Stainless steel A2-70
19	Adjustment nut	AISI 316L / 1.4404
20	Adjustment screw	Brass
21	O-ring	NBR
22	Bearing	Corrosion resistant steel
23	Shaft ring	Stainless steel
24	Cover nut	Plastic
25	* O-ring	EPDM

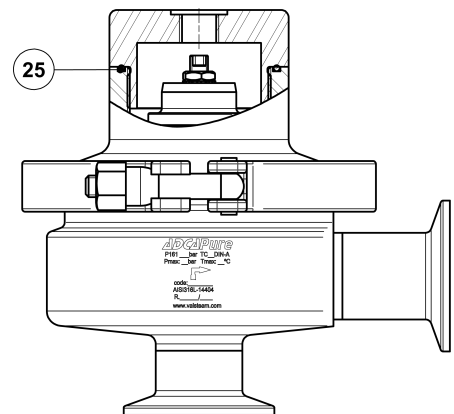
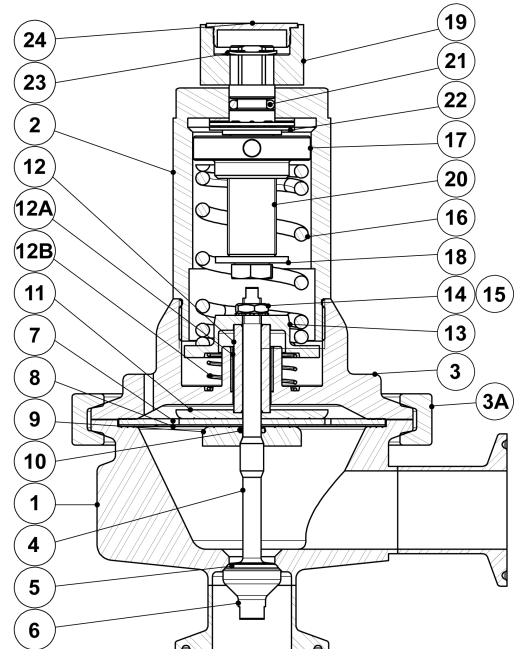

Optional dome-loaded version (1/4")

\* Available spare parts; \*\* Others on request.

Remarks: FDA / USP Class VI seals certificate on request.

All valves have a serial number. In case of non-standard valves, this number must be supplied if spare parts are ordered.

**OPTIONS**

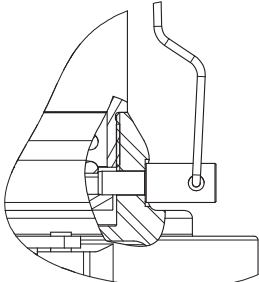
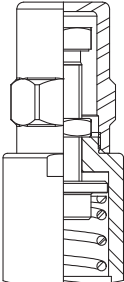
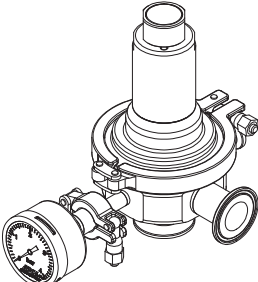
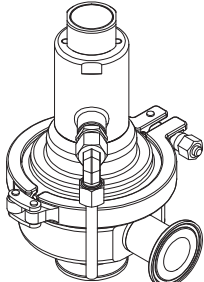
LOCK SYSTEM	ADJUSTMENT SCREW WITH TOP CAP	PRESSURE GAUGE CONNECTION	LEAKAGE LINE CONNECTION
			

ORDERING CODES P161

Valve model	P16	1	3	1	T	M	I	X	X	X	DI	15	E
P161 – AISI 316L / 1.4404 diaphragm sensing pressure reducing valve	P16												
<b>Valve series</b>													
Series 1		1											
<b>Regulating range</b>													
0,3 to 1,1 bar			3										
0,8 to 1,5 bar			4										
1 to 3 bar			5										
1,5 to 5 bar			6										
0,8 to 5 bar (dome-loaded) <b>a)</b>			A										
0,3 to 1,1 bar (dome-loaded) <b>a)</b>			B										
<b>Flow rate coefficient</b>													
Kvs 1,3 (only applicable to ASME BPE 1/2" size)				1									
Kvs 2,1 (applicable to sizes DIN DN 15 and ISO DN 15)				2									
Kvs 3 (applicable to sizes ASME BPE 3/4" and DIN DN 20)				3									
Kvs 4,2 (applicable to sizes ASME BPE 1", DIN DN 25 to DN 32 and ISO DN 20 to DN 25)				4									
Kvs 7 (applicable to sizes ASME BPE 1 1/2" to 2", DIN DN 40 to DN 50 and ISO DN 32 to DN 40)				6									
Kvs 13 (applicable to sizes ASME BPE 2" and DIN DN 50)				8									
<b>Diaphragm</b>													
PTFE (Gylon)					T								
EPDM (non-standard)					E								
<b>Seat material b)</b>													
Metal to metal (non-standard, except in ASME BPE 1/2" size)						M							
EPDM							E						
PTFE								T					
FPM / Viton (FDA approval only)									V				
<b>Adjustment knob, top cap and leakage line connection</b>													
Stainless steel adjustment knob							I						
Top cap (adjustment screw with cover)								T					
Stainless steel adjustment knob w/ diaphragm cover leakage connection in case of diaphragm failure									L				
Top cap (adjustment screw with cover) w/ diaphragm cover leakage connection in case of diaphragm failure										U			
Dome-loaded top <b>c)</b>											X		
<b>Gauge port options</b>													
Without gauge ports											X		
Tri-clamp gauge port on the left side (rel. to the flow direction) – downstream pressure												7	
Tri-clamp gauge port on the right side (rel. to the flow direction) – downstream pressure													6
Tri-clamp gauge port on both sides – downstream pressure													5
Threaded gauge port on the left side (rel. to the flow direction) – downstream pressure – ISO 7 Rp 1/4"													4
Threaded gauge port on the right side (rel. to the flow direction) – downstream pressure – ISO 7 Rp 1/4"													3
Threaded gauge port on both sides – downstream pressure – ISO 7 Rp 1/4"													2
Threaded gauge port on the left side (rel. to the flow direction) – downstream pressure – 1/4" NPT													W
Threaded gauge port on the right side (rel. to the flow direction) – downstream pressure – 1/4" NPT													Y
Threaded gauge port on both sides – downstream pressure – 1/4" NPT													Z
<b>Surface finish d)</b>													
Standard surface finish												X	
Mirror mechanical polished external surfaces (SF1)													P
Electropolished internal wetted parts (SF5)													E
<b>Special features</b>													
None													X
Degreased for oxygen													O
CIP / SIP lock system													C
<b>Pipe connections</b>													
Clamp ferrule ASME BPE													D
Clamp ferrule DIN (DIN 32676-A)													F
Clamp ferrule ISO (DIN 32676-B)													E
Tube weld (ETO) according to ASME BPE													DI
Tube weld (ETO) according to DIN 11866-A (DIN 11850-2)													FI
Tube weld (ETO) according to DIN 11866-B (ISO 1127)													EI
<b>Size</b>													
1/2" or DN 15													15
3/4" or DN 20													20
1" or DN 25													25
DN 32													32
1 1/2" or DN 40													40
2" or DN 50													50
<b>Special valves / Extras</b>													
Full description or additional codes have to be added in case of a non-standard combination													E

**a)** The loading control pressure can be up to a maximum of 0,2 bar above the required downstream pressure; **b)** ASME BPE 1/2" size is only available with metal to metal sealing; **c)** Must be chosen in case of dome-loaded version; **d)** Consult IS PV20.00 – Technical information – for further details and other surface finish options.