

CBS TANK CONNECTORS

For air breathers with spin-on cartridge

Working Temperature

From -25° to +110° C

Compatibility (ISO 2943:1999)

Full with fluids: HH - HL - HM - HR - HV - HG (according to ISO 6743/4)

For fluids different than the above mentioned, please contact our Sales Department.

Materials

Connector: Steel (zinc plated for the flanged version)
 Cartridge can: Steel
 Filter media: Standard - CC = Cellulose
 On request - FD = Inorganic fiber
 Filtration degree (in air): 3µm

Article No.	Description	Price £	Price €
CBS11WWXCC		ON REQUEST	
CBS12WWXCC	WITH WELDING CONNECTION	ON REQUEST	
CBS21WWXCC		ON REQUEST	
CBS22WWXCC		ON REQUEST	
CBS11SWCCC		ON REQUEST	
CBS12SWCCC	WITH FLANGED CONNECTION	ON REQUEST	
CBS21SWCCC		ON REQUEST	
CBS22SWCCC		ON REQUEST	



Dwg. A
Welding connector

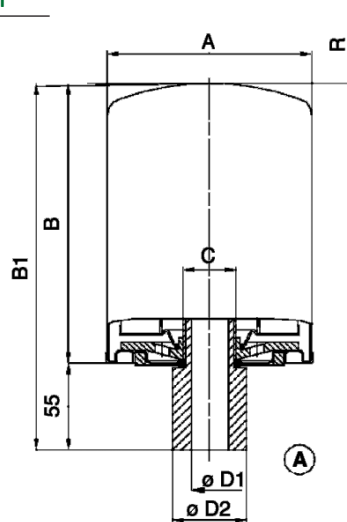

Dwg. B
Flanged connector

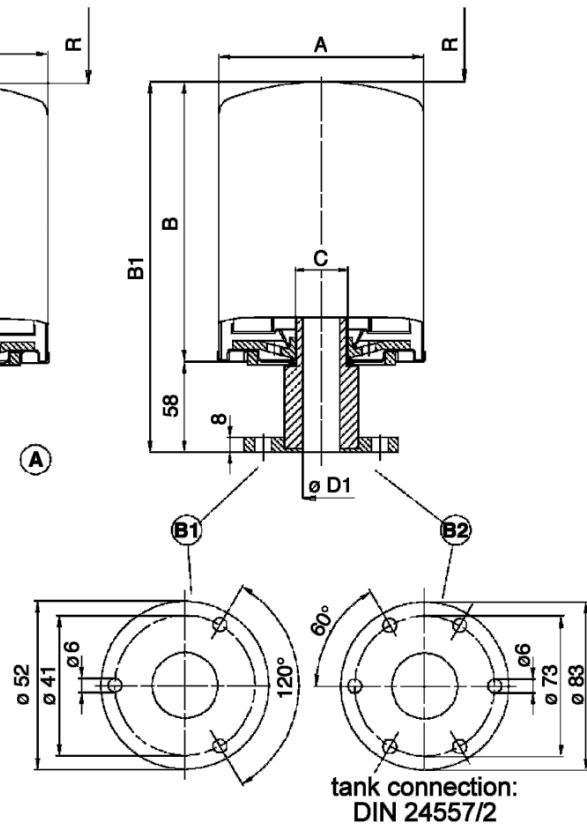

DIMENSIONS

Cellulose = CC Inorganic fiber = FD	Dwg.	Flow rate (l/min)	A	B	B1	C	D1	D2	R	
CBS11WWX	□□	A	1.800	96	146	201	3/4" BSP	18	32	40
CBS12WWX	□□	A	1.800	96	191	246	3/4" BSP	18	32	40
CBS21WWX	□□	A	2.800	129	181	236	1 1/4" BSP	32	48	40
CBS22WWX	□□	A	2.800	129	226	281	1 1/4" BSP	32	48	40
CBS11SWC	□□	B1	1.800	96	146	204	3/4" BSP	18	-	40
CBS12SWC	□□	B1	1.800	96	191	249	3/4" BSP	18	-	40
CBS21SWC	□□	B2	2.800	129	181	239	1 1/4" BSP	32	-	40
CBS22SWC	□□	B2	2.800	129	226	284	1 1/4" BSP	32	-	40