

# PRESSURE FILTER - PA

**110 Bar Rated - flows to 80 lpm**

## Pressure (ISO 10771-1:2002)

Max working: 11 MPa (110 bar)  
 Test: 16 MPa (160 bar)  
 Bursting: 30 MPa (300 bar)  
 Collapse, differential for the filter element (ISO 2941): 8 MPa (80 bar)

## Bypass Valve

Setting: 600 kPa (6 bar) ± 10%

## Working Temperature

From -25° to +110° C

## Compatibility (ISO 2943:1999)

Full with fluids: HH-HL-HM-HV-HTG (according to ISO 6743/4)  
 For fluids different than the above mentioned, please contact our Sales Department.

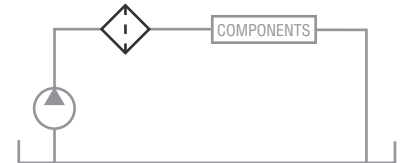

## Materials

Housing: Anodized aluminium alloy  
 Bypass valve: Brass  
 Seals: NBR Nitrile  
 (FKM - on request fluoroelastomer)  
 Indicator housing: Brass

## Application Example



## FOR ELEMENT PART NUMBER

- E** - ELEMENT
- PA** - FILTER FAMILY SERIES
- 11** - FILTER HOUSING SIZE
- CC** - ELEMENT MEDIA

Example:

Part **EPA11CC** : element in 10 micron cellulose media for a size "11" housing

## HOUSINGS

Body Size	Connection	Article No	Flow Rate Max Lpm	Price £	Price €
PA11	1/2"	PA11		ON REQUEST	Body without bypass valve
PA12	1/2"	PA12		ON REQUEST	
PA11	1/2"	PA11B		ON REQUEST	Body with 6 BAR bypass valve
PA12	1/2"	PA12B		ON REQUEST	

## ELEMENT to be added

Element	Size	Filtration	Max LPM	Article No.	Price £	Price €
FA	11	5 micron	6 LPM	EPA11FA	ON REQUEST	
FB	11	7 micron	9 LPM	EPA11FB	ON REQUEST	
FC	11	12 micron	14 LPM	EPA11FC	ON REQUEST	
FD	11	21 micron	22 LPM	EPA11FD	ON REQUEST	
CC	11	10 micron	40 LPM*	EPA11CC	ON REQUEST	
FA	12	5 micron	12 LPM	EPA12FA	ON REQUEST	
FB	12	7 micron	18 LPM	EPA12FB	ON REQUEST	
FC	12	12 micron	28 LPM	EPA12FC	ON REQUEST	
FD	12	21 micron	45 LPM	EPA12FD	ON REQUEST	
CC	12	10 micron	80 LPM*	EPA12CC	ON REQUEST	

\*BYPASS HOUSING REQUIRED

## CLOGGING INDICATOR

Indicator	Code	Pressure	Price
NONE - PLUGGED	O3		ON REQUEST
VISUAL BUTTON	5E		ON REQUEST
ELECTRICAL	6E	5 BAR CRACKING PRESSURE	ON REQUEST
ELECTRICAL WITH LED	7E		ON REQUEST
ELECTRICAL WITH THERMOSTAT	T2		ON REQUEST
VISUAL & ELECTRICAL	72		ON REQUEST

# PRESSURE FILTER - PA

110 Bar Rated - flows to 80 lpm

## Ordering Codes - Filter

		<b>Type</b>			
		F = Filter Complete	F	F	
		B = Filter Housing	B	B	
P	A	<b>Family, Nominal Size, Length</b>		11	12
		<b>Port Type</b>			
		B = BSP Thread	B	B	
		N = NPT Thread	N	N	
		S = SAE Thread	S	S	
0	4	<b>Port Size</b>			
		04 = 1/2"	04	04	
		<b>Bypass Valve</b>			
		W = Without	W	W	
		C = 600 kPa (6 bar)	C	C	
		<b>Seals</b>			
		N = NBR Nitrile	N	N	
		F = FKM Fluoroelastomer	F	F	
		<b>Filter Media</b>			
		CC = Cellulose 10~µm β>2	CC	CC	
		FA = Fibre 5µm <sub>(c)</sub> β>1.000	FA	FA	
		FB = Fibre 7µm <sub>(c)</sub> β>1.000	FB	FB	
		FC = Fibre 12µm <sub>(c)</sub> β>1.000	FC	FC	
		FD = Fibre 21µm <sub>(c)</sub> β>1.000	FD	FD	
		<b>Clogging Indicator</b>			
		03 = Port, plugged	03	03	
		5E = Visual Differential 500 kPa (5 bar)	5E	5E	
		6E = Electrical Differential 500 kPa (5 bar)	6E	6E	
		7E = Indicator 6E with LED	7E	7E	
		T2 = Elect. diff 500 kPa (5 bar) with thermostat 30°C	T2	T2	
X	X	<b>Accessories XX = no access available</b>		XX	XX

## Ordering Codes - Element

		<b>Element</b>			
P	A	<b>Family, Nominal Size, Length</b>		11	12
		<b>Seals</b>			
		N = NBR Nitrile	N	N	
		F = FKM Fluoroelastomer	F	F	
		<b>Filter Media</b>			
		CC = Cellulose 10µm β>2	CC	CC	
		FA = Fibre 5µm <sub>(c)</sub> β>1.000	FA	FA	
		FB = Fibre 7µm <sub>(c)</sub> β>1.000	FB	FB	
		FC = Fibre 12µm <sub>(c)</sub> β>1.000	FC	FC	
		FD = Fibre 21µm <sub>(c)</sub> β>1.000	FD	FD	

## Dimensions (mm) - FILTER ELEMENT

	A	B	C	kg	Area (cm <sup>2</sup> )	
					media F+	media C+
EPA11	22	42	91	0.15	295	295
EPA12	22	42	179	0.25	600	600

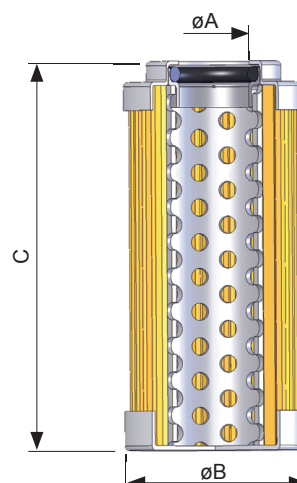

# PRESSURE FILTER - PA

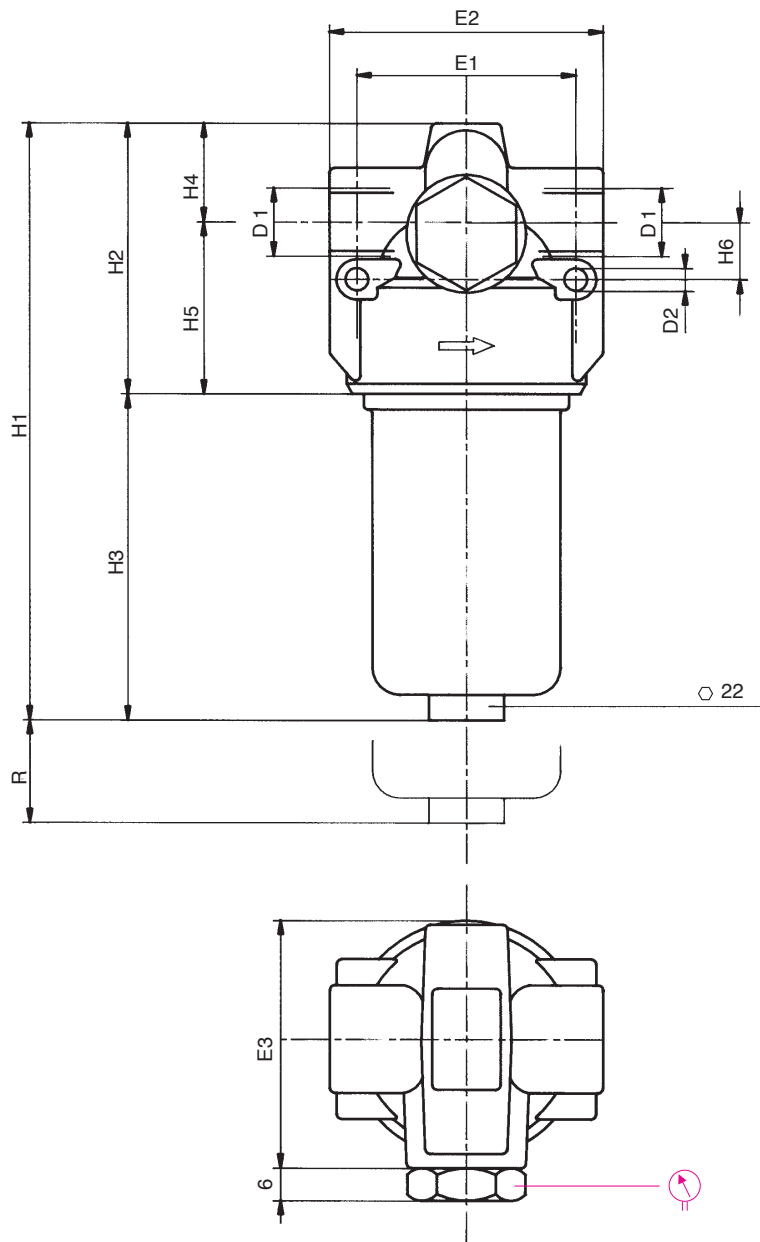

Dimensions (mm) - FILTER HOUSING

	D1	D2	H1	H2	H3	H4	H5	H6	E1	E2	E3	R	kg
FPA11	1/2"	6.5	157	78	79	28	50	17	64	76	75	60	0.65
FPA12	1/2"	6.5	244	78	166	28	50	17	64	76	75	60	0.85

# PRESSURE FILTER - PA

## PRESSURE DROP CURVES ( $\Delta p$ )

The "Assembly Pressure Drop ( $\Delta p$ )" is obtained by adding the pressure drop values of the Filter Housing and of the Clean Filter Element corresponding to the considered Flow Rate and it must be lower than 80 kPa (0,8 bar).

**FILTER HOUSING PRESSURE DROP**  
(mainly depending on the port size)

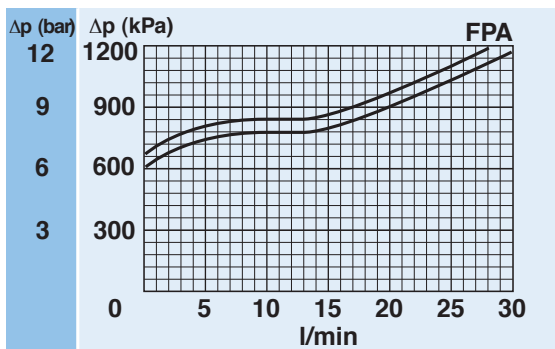

**FILTER HOUSING PRESSURE DROP**  
(mainly depending on the port size)

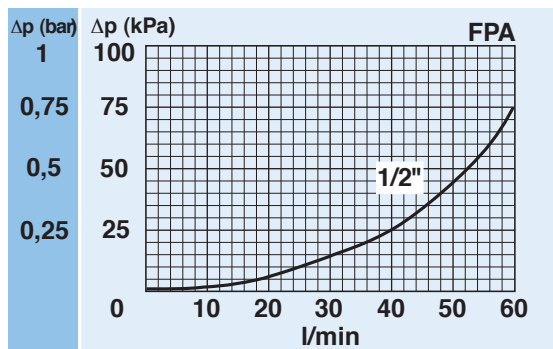

**CLEAN FILTER ELEMENT PRESSURE DROP WITH F+ AND C+ MEDIA**  
(depending both on the internal diameter of the element and on the filter media)

