

HYGIENIC BALL VALVES M3H TRUE BORE (2 1/2" – 4" ASME BPE)

DESCRIPTION

M3H three piece body ball valves are isolating valves designed for use with clean steam, condensate and other gases and liquids used in high purity and aseptic processes.

The valve is not designed as a control valve and should only be used as an isolating valve, fully open or fully closed.

The product is mainly designed for the pharmaceutical, biotech, semiconductor, cosmetics, fine chemical, food and beverage industries.

MAIN FEATURES

True bore floating ball design.

A351 CF3M body and ends with ferrite content of less than 2% and low sulphur between 0,005 and 0,017%.

Can be serviced without removal from pipeline.

Tube weld with loose body flanges (360° rotation after installation).

Bidirectional.

Antistatic device.

Anti blow out proof stem.

ISO 5211 mounting.

STANDARD SURFACE FINISH

Internal wetted parts: ≤ 0,51 micron Ra – SF1.

External: as casted.

Ultrasonic cleaning.

OPTIONS: Different sealing materials.
Degreased for oxygen use.
Cavity filler.

USE: Clean steam, gases and liquids compatible with the construction.

AVAILABLE MODELS: M3H – Investment casting.

SIZES: 2 1/2" to 4".

CONNECTIONS: According to ASME BPE.
TC – Sanitary clamps.
ETO – Extended tube orbital welding.
TC / ETO – Combination.

PACKAGING: Assembling and packaging in a clean room certified according to ISO 14644-1.
The product is end capped and sealed with recyclable thermo-shrinkable plastic film, to avoid contamination.

INSTALLATION: See IMI - Installation and maintenance instructions.

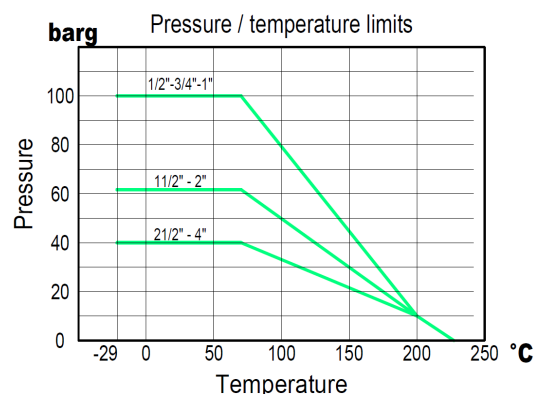

TFM 1600

Note: Working pressure may be limited by the valve connections.

| CE MARKING – GROUP 2 (PED – European Directive) | |
|--|---------------|
| PN40 | Category |
| 2 1/2" to 4" | 1 (CE marked) |

DIMENSIONS (mm) ASME BPE

| SIZE | A1 | A2 | A3 | A3.1 | A3.2 | B | C | D | E | F | G | H | I | BALL PORT | ISO 5211 | WGT. (kg) |
|--------|-----|-----|-------|------|-------|-----|-------|-----|-----|------|-------|------|----|-----------|----------|-----------|
| 2 1/2" | 190 | 203 | 196,3 | 95 | 101,5 | 160 | 72,5 | 169 | 400 | 77,5 | 63,5 | 60,2 | 37 | 60,2 | F7 | 13,3 |
| 3" | 216 | 228 | 222 | 108 | 111 | 180 | 83,5 | 180 | 400 | 91 | 76,2 | 72,9 | 38 | 72,9 | F7 | 18,6 |
| 4" | 254 | 267 | 260,5 | 127 | 133,5 | 220 | 101,5 | 198 | 400 | 119 | 101,6 | 97,4 | 44 | 97,4 | F10 | 29,6 |

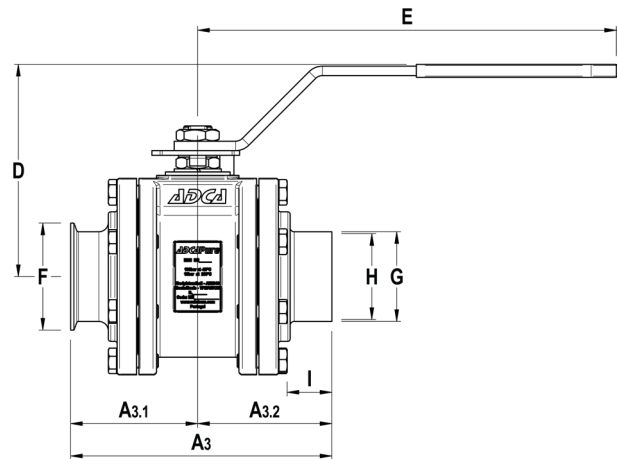
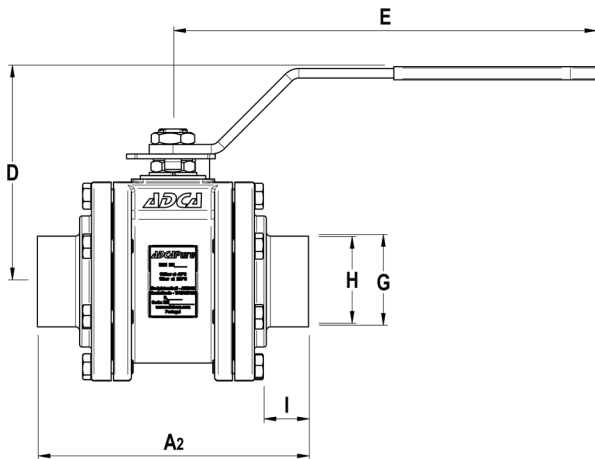
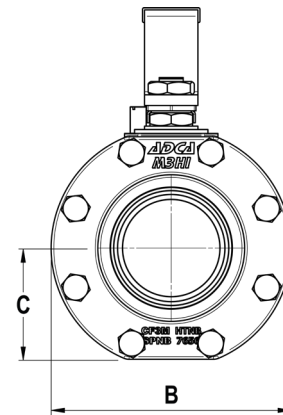
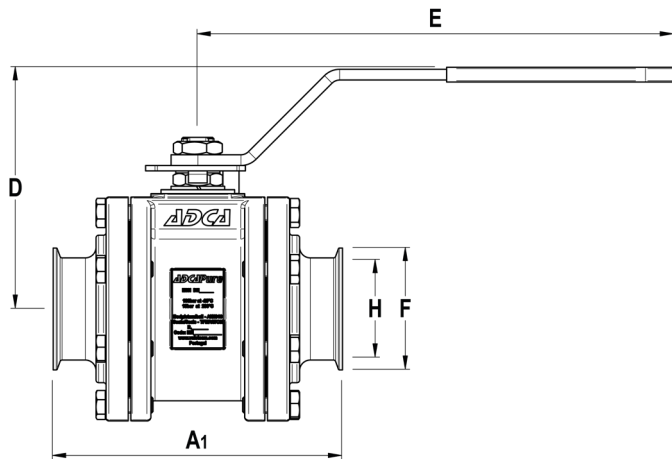

Tube weld easy and quick installation - standard

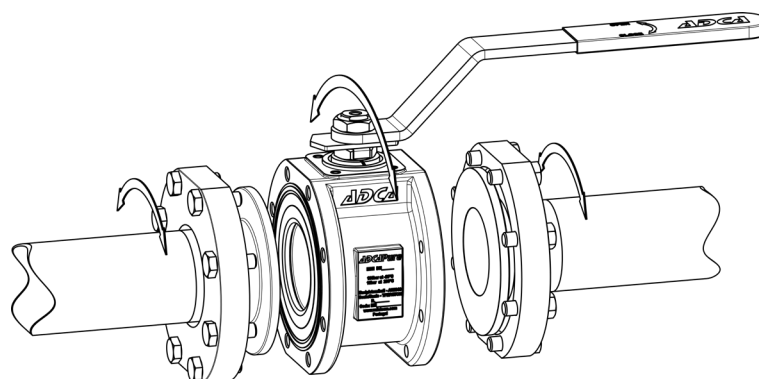

Loose body flanges make it possible to install the valve without aligning of the welded end connections. After installation the valve can rotate on 360° for the desired orientation.

MATERIALS

| POS. N° | DESIGNATION | MATERIAL |
|---------|--------------------------|--------------------|
| 1 | Valve body | CF3M / 1.4409 |
| 2 | TC end connection | CF3M / 1.4409 |
| 3 | Tube weld end connection | AISI 316L / 1.4404 |
| 4 | ** Flange | AISI 316L / 1.4404 |
| 5 | Stem | AISI 316L / 1.4404 |
| 6 | * Valve ball | AISI 316L / 1.4404 |
| 7 | * Standard seat | TFM 1600 |
| 8 | * Cavity filler seat | TFM 1600 |
| 9 | Body ring | AISI 316L / 1.4404 |
| 10 | * Body seal | PTFE |
| 11 | * Stem seals | TFM 1600 |
| 12 | * Spacer | AISI 316 / 1.4401 |
| 13 | Handle | AISI 304 / 1.4301 |
| 14 | Handle end | Vinyl |
| 15 | * Spring washers | AISI 304 / 1.4301 |
| 16 | Compression nut | AISI 304 / 1.4301 |
| 17 | * Lock washer | AISI 304 / 1.4301 |
| 18 | Fixing bolt | AISI 304 / 1.4301 |
| 19 | Stop pin | AISI 304 / 1.4301 |
| 20 | Handle stopper | AISI 304 / 1.4301 |
| 21 | Antistatic device | AISI 316 / 1.4401 |
| 22 | O-ring | Viton |

* Available spare parts;

** Loose flange. Allows a 360° rotation of the valve when using tube weld connections.

Remarks: FDA / USP Class VI seals certificate on request.

All valves have a serial number. In case of non-standard valves, this number must be supplied if spare parts are ordered.

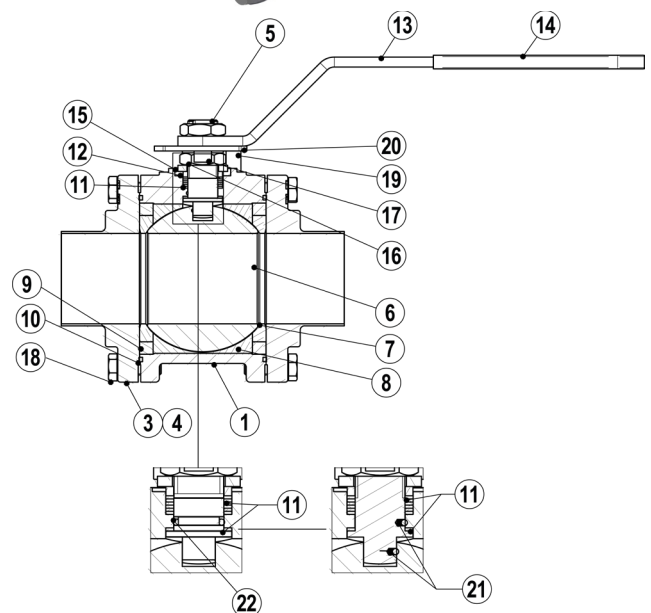
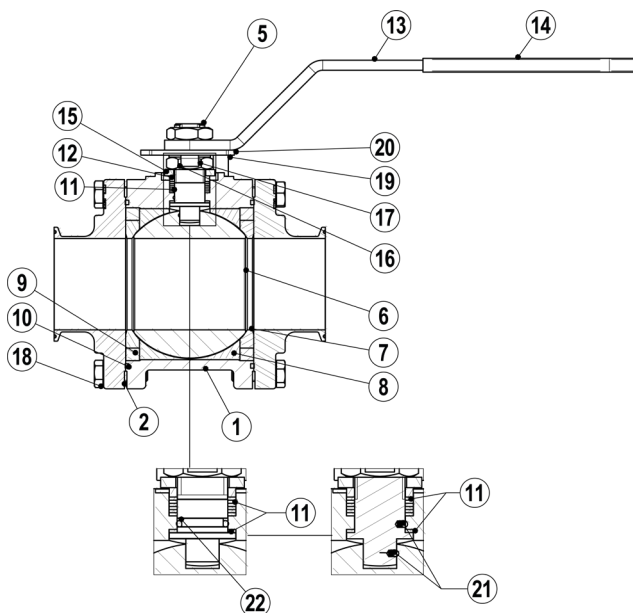
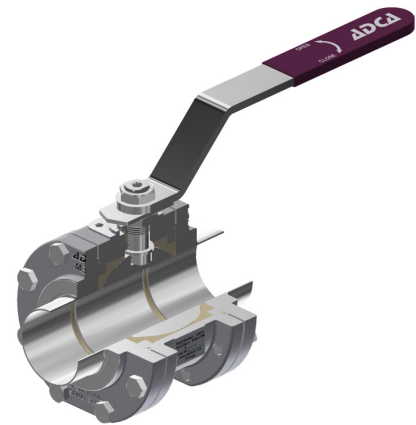
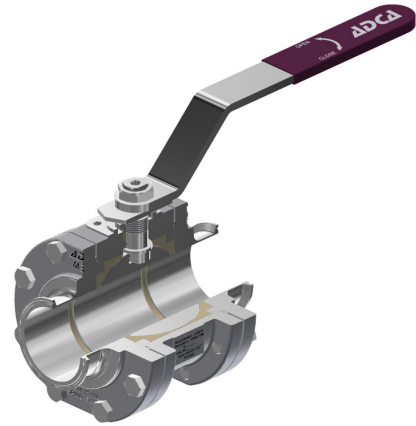

| ORDERING CODES M3H | | | | | | | | | | | |
|---|----|---|---|---|---|---|---|----|-----|----|-----|
| Valve model | MH | X | X | X | F | X | X | CB | X | 65 | |
| M3H 3 pieces ball valve CF3M | MH | | | | | | | | | | |
| | | | | | | | | | | | |
| Lever handle | | | | | | | | | | | |
| Flat lever handle stainless steel / plastic cover | | X | | | | | | | | | |
| Flat lever handle stainless steel / plastic cover w/ lockable system | | 3 | | | | | | | | | |
| Bare stem | | 9 | | | | | | | | | |
| Material | | | | | | | | | | | |
| CF3M / 1.4409 | | | X | | | | | | | | |
| Seat design | | | | | | | | | | | |
| Standard seats | | | | X | | | | | | | |
| Cavity fillers | | | | | F | | | | | | |
| Seat material | | | | | | | | | | | |
| TFM 1600 | | | | | F | | | | | | |
| Surface finish (a) | | | | | | | | | | | |
| Standard surface finish | | | | | | X | | | | | |
| Electropolished internal wetted parts (SF5) | | | | | | E | | | | | |
| Special features | | | | | | | | | | | |
| None | | | | | | | | X | | | |
| Oxygen cleaning | | | | | | | | O | | | |
| End connections | | | | | | | | | | | |
| TC – Sanitary clamps ASME BPE | | | | | | | | | CB | | |
| ETO – Extended tube orbital welding ASME BPE (360° rotation design) | | | | | | | | | TB | | |
| TC / ETO – Combination ASME BPE (360° rotation design) | | | | | | | | | CTB | | |
| Ball port | | | | | | | | | | | |
| True bore (standard) | | | | | | | | | | X | |
| Full bore | | | | | | | | | | | NA |
| Size | | | | | | | | | | | |
| 2 1/2" | | | | | | | | | | | 65 |
| 3" | | | | | | | | | | | 80 |
| 4" | | | | | | | | | | | 100 |
| Special valves / Extras | | | | | | | | | | | |
| Full description or additional codes have to be added in case of a non standard combination | | | | | | | | | | | E |

(a) Consult IS PV20.00 (Technical information) for further details and other surface finish options.

NA – Not available.